

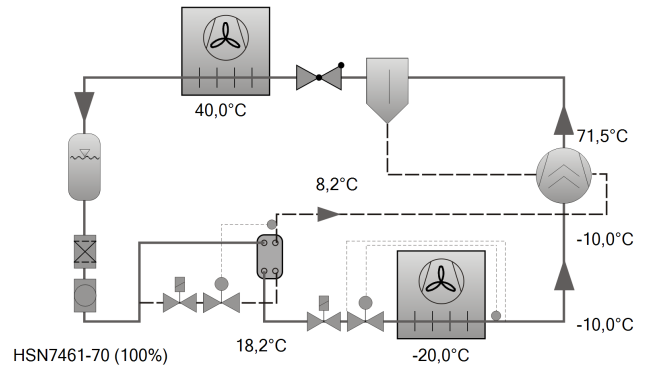

### Selection: Semi-hermetic Screw Compressors HS

#### Input Values

Compressor model	HSN7461-70
Refrigerant	R404A
Reference temperature	Dew point temp.
Evaporating SST	-20,00 °C
Condensing SDT	40,0 °C
Liq. subc. (in condenser)	0 K
Auto. subcooling	Auto
Suct. gas superheat	10,00 K
Operating mode	Economiser
Power supply	400V-3-50Hz
Useful superheat	100%
Additional cooling	Automatic
Max. discharge gas temp.	80,0 °C



#### Result

Compressor	HSN7461-70-40P
Capacity steps	100%
Cooling capacity	114,8 kW
Cooling capacity *	118,2 kW
Evaporator capacity	114,8 kW
Power input	57,0 kW
Current (400V)	91,0 A
Voltage range	380-415V
Condenser capacity	171,8 kW
COP/EER	2,02
COP/EER *	2,06
Mass flow LP	3006 kg/h
Mass flow HP	3842 kg/h
Operating mode	Economiser
Liquid temp. (sc)	18,18 °C
Mass flow ECO	837 kg/h
sub cooler load	27,9 kW
sat. ECO Temp.	8,18 °C
ECO pressure	7,77 bar(a)
Oil volume flow	1,87 m³/h
Cooling method	--
Discharge gas temp. w/o cooling	71,5 °C

\*According to EN12900 (10K suction gas superheat, liquid subcooling in Economiser with 5K temperature difference)

#### Application Limits ECO HSN7461-70

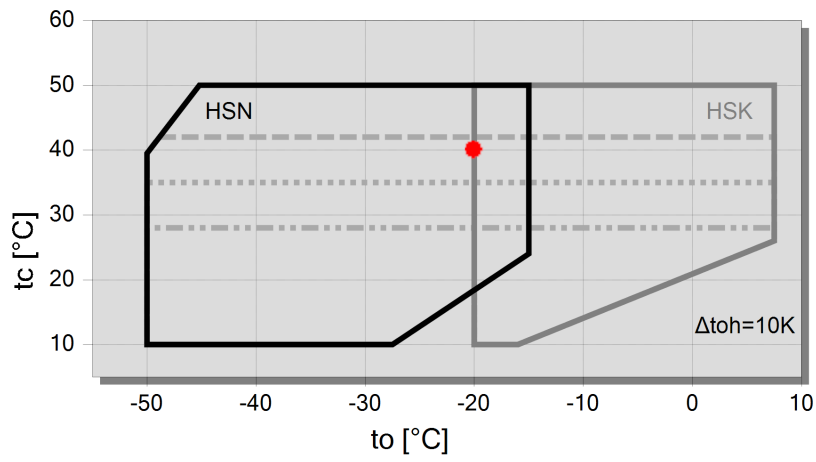

**Legend**

- max.  $t_c$  for frequencies = 20Hz
- ..... max.  $t_c$  for frequencies = 25Hz
- max.  $t_c$  for frequencies = 35Hz
- A



## Technical Data: HSN7461-70

### Dimensions and Connections

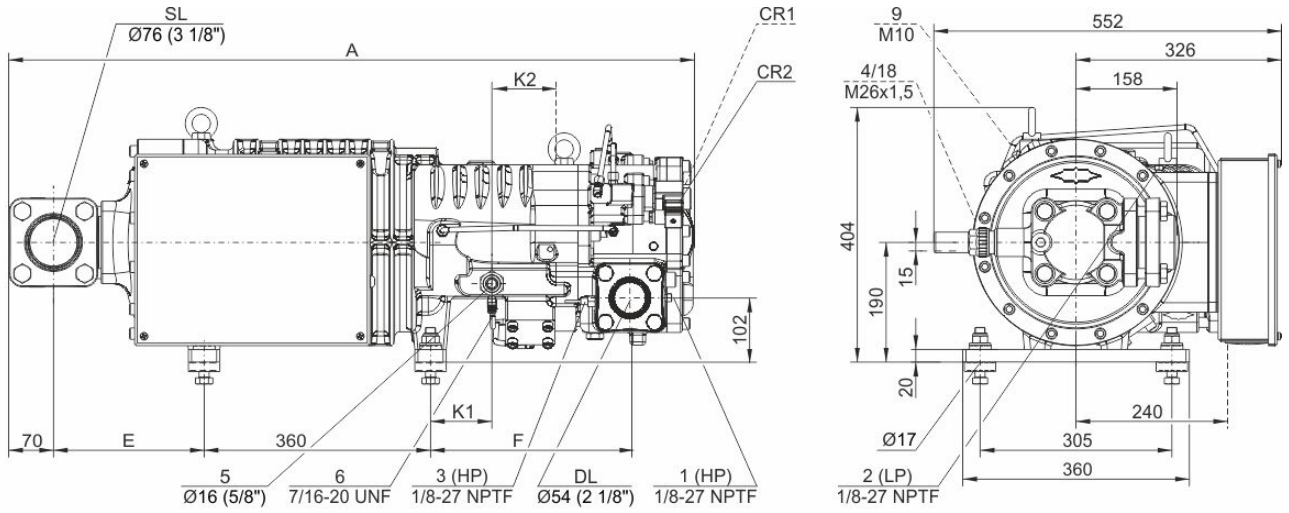

Model	A	E	F	K1	K2
	mm	mm	mm	mm	mm
HS.7451, HS.7461	1021	186	295	76	109
HSK7471-70, HSN7471-75	1034	186	318	98	97
HSK7471-90	1087	238	318	98	97



## Technical Data

### Technical Data

Displacement (2900rpm 50 Hz)	220 m <sup>3</sup> /h
Displacement (3500rpm 60 Hz)	266 m <sup>3</sup> /h
Weight	310 kg
Max. pressure (LP/HP)	19 / 28 bar
Connection suction line	76 mm - 3 1/8"
Connection discharge line	54 mm - 2 1/8"
Adapter/shut-off valve for ECO	22 mm - 7/8" (Option)
Oil type R22	B150SH, B100 (Option)
Oil type R134a/R404A/R507A/R407A/R407F	BSE170
Oil type R448A/R449A/R454C	BSE170

### Motor data

Motor version	1
Motor voltage (more on request)	380-415V PW-3-50Hz
Max. operating current	124.0 A
Starting current (Rotor locked)	290.0 A D / 485.0 A DD
Max. power input	75,0 kW

### Extent of delivery (standard)

Discharge gas temperature sensor	Standard
Start unloading	Standard
Oil flow control	SE-B3 (Standard)
Motor protection	SE-E1 (Standard), SE-E3 (Standard for 660-690V)
Suction shut-off valve	Standard
Capacity control	100-75-50% (Standard)
Enclosure class	IP54

### Available options

Discharge shut-off valve	Option
ECO connection with shut-off valve	Option
Motor protection	SE-i1 (200-690V)

### Sound measurement

Sound power level (-35°C / 40°C)	88,5 dB(A)
Sound pressure level @ 1m (-35°C / 40°C)	80,5 dB(A)



## Semi-hermetic Screw Compressors HS

**HSK** = Application for air-conditioning and medium temperature cooling.

**HSN** = Application for low temperature cooling.

### Notes regarding application limits (see "Limits")

- \* Ranges are valid for standard operation and at full-load conditions.
- \* With high pressure conditions, part-load operation is partly limited (see application limits in applications manual SH-100).
- \* With Economizer operation the maximum admissible evaporation temperature is shifted by 10K downward (otherwise there is a danger of excessive compression and overload of the motor because of a higher mass flow). At pull-down conditions from higher evaporation temperatures, the ECO injection must remain closed until the evaporation temperature is below the maximum admissible value and a stable operation is achieved (e.g. control of the ECO solenoid valve by means of a low pressure cut-out). The use of the ECO-system with higher evaporation temperatures requires individual consultation with Bitzer.

### HS 64/74

- \* Capacity control with ECO operation at the same time is limited to one single regulating step (CR 75%). At CR 50% the ECO injection should be closed.

### Data for sound emission

Data are based on 50Hz application (IP-units 60Hz) and R404A.

Sound pressure level: values are based on open air test sites with semi-spherical sound emissions at 1 meter distance. For further information see Technical Information "Sound Data".